

EASY ROOF

Installation Instruction

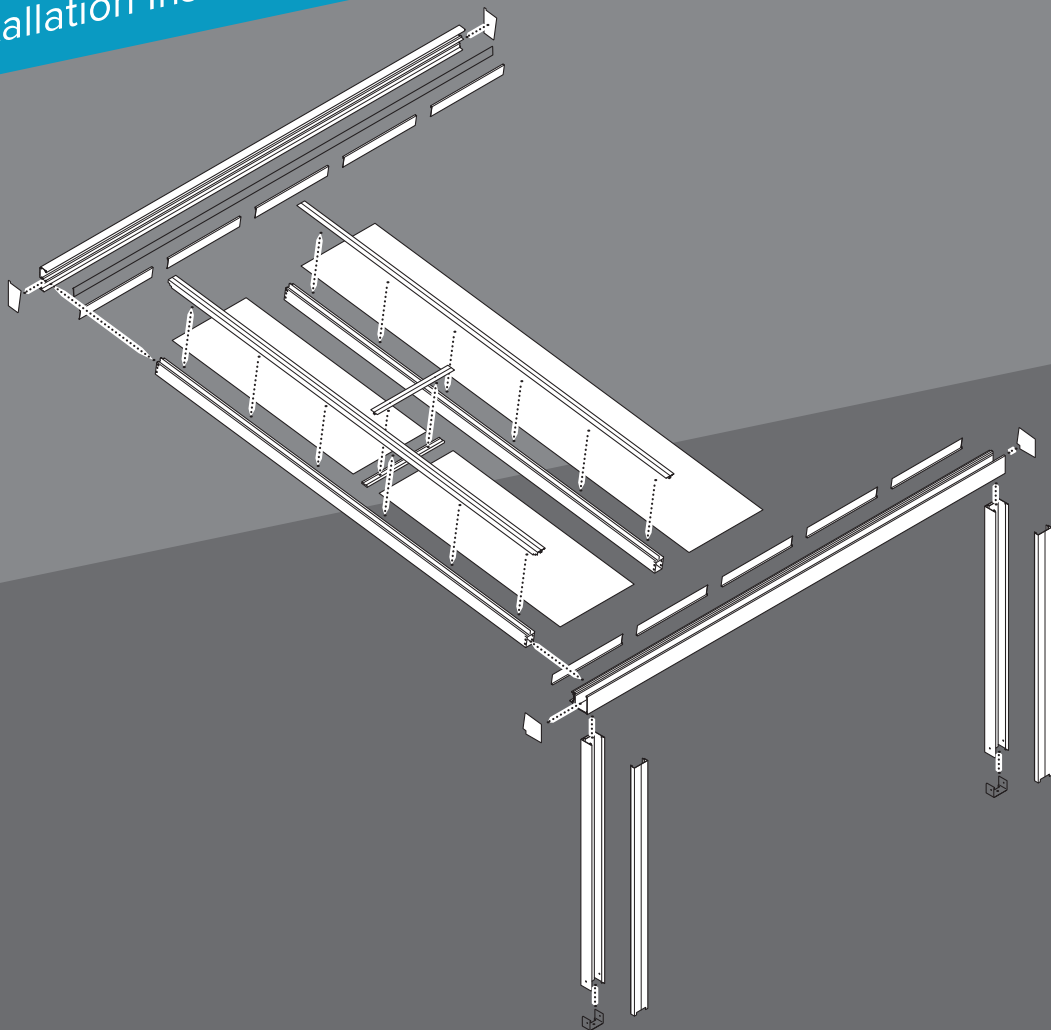

CONTENT

1	Introduction	3
1.1	Purpose of the operating instructions	3
1.2	Limitation of liability	3
1.3	Copyright	3
1.4	Layout of the manual	4
2	Safety	5
2.1	Qualifications of the assembly and maintenance personnel	5
2.2	Intended use	5
2.3	Personal protective equipment (PPE)	5
2.4	Spare parts	5
2.5	General safety information	6
3	Transport & storage	6
4	Main components and profiles	7
5	Preparations for assembly	9
5.1	Tools required for assembly	9
5.2	Personal Protective Equipment (PPE) required for assembly	9
6	Installation steps	10
7	Dimensions	21
8	Cleaning and care	22
9	Maintenance	23
10	Disposal	23

1 Introduction

1.1 Purpose of the operating instructions

Read the following information carefully before you start working with the product and keep the instructions in a safe place!

These instructions contain all the necessary information concerning safety, transport, assembly, operation and maintenance of the product, which are necessary for safe working with the product as intended by the manufacturer.

Following the instructions helps to avoid hazards, increase the reliability and service life of the product and minimise the need for repair work.

1.2 Limitation of liability

Pergola Room USA LLC cannot be held liable for damages or injuries caused by the following misuse:

- Non-intended use
- Improper assembly
- Failure to observe the instructions and safety information in this manual
- Maintenance and installation by unqualified personnel
- Unauthorised changes
- Technical modifications
- Use of spare parts not recommended by the manufacturer

The end user is responsible for assembling and using the product properly. The warranty shall become void if the product and/or the electrical components are damaged due to improper assembly or use.

1.3 Copyright

This document is protected by copyright. It is legally prohibited to distribute this manual to third parties, reproduce it in any form including excerpts, as well as to use or disclose any of its contents without the express permission of the publisher. Violations shall lead to liability for damages. Pergola Room reserves the right for further claims.

1.4 Layout of the manual

Warnings

This manual provides information on the following by means of warnings:

- Hazards that may occur in the situation in question
- Consequences if the hazard is not avoided
- Measures to avoid the hazards
- Section-related warnings about injuries and section-related warnings about property damage have a different layout. They look like this:

Signal words

The signal word is part of a warning and indicates the severity of a hazard.



Denotes a potentially dangerous situation which could result in death or serious injury unless avoided.



Denotes a potentially dangerous situation which could result in minor injury unless avoided.



Denotes a prompt to carry out an activity or a piece of information about characteristics, failure to observe which could result in material damage.

Safety symbols

General warning sign

The general warning sign indicates a general hazard.



General warning sign

Specific warning sign

Specific warning signs make a hazard clear.



Danger of falling



Risk of injury from suspended loads

2 Safety

2.1 Qualifications of the assembly and maintenance personnel

The product may only be assembled and maintained by people with knowledge in the following areas:

- Regulations on fixing and sealing construction elements
- Load transfer and fixing methods
- Installation of fixing elements
- Evaluation of the building material
- Lifting and transporting loads
- Handling ladders and scaffolds
- Handling tools and machines
- Product functionality

Furthermore, the information in the implementation plans must be checked before installation.

2.2 Intended use

Glass roofs

Glass roofs may only be used for roofing terraces. Free-standing glass roofs or those combined with Pergola Room sliding, folding and stacking walls must be designed accordingly at the planning stage.

All-glass systems

All-glass systems may only be used as a closure for terrace roofs, verandas, garden houses, log cabins, balconies, etc.

2.3 Personal protective equipment (PPE)

Personal protective equipment must always be used if its use is prescribed by the following:

- ▶ by the manual/instructions
- ▶ by warning signs

The installer must use the protective equipment as prescribed and are responsible for ensuring that it is stored and kept in good condition.

2.4 Spare parts

To ensure safe operation, use only the spare parts specified by the manufacturer. Otherwise, all warranty and liability claims against the manufacturer will be voided.

2.5 General safety information



⚠ WARNING Risk of injury due to improper assembly and use!

- ▶ Before stepping on the roof surface, check with the roofing supplier whether the roof surface has the appropriate load-bearing capacity.
- ▶ Wear personal protective equipment (PPE) during all assembly work.
- ▶ The statics of the roof and foundation, as well as the fixation to the building, must be checked in advance.
- ▶ Assembly work may only be carried out by qualified personnel and must comply with local laws and regulations.



⚠ WARNING Risk of injury and falling when working at height!

- ▶ Use a ladder or platform when working at height.
- ▶ Ensure that assembly personnel are secured with a safety harness.
- ▶ Cover and secure the edges you might fall on with suitable materials.



⚠ CAUTION Risk of injury from lifting heavy loads!

- ▶ The individual elements of the product must always be lifted by at least two persons or by means of a mechanical lifting aid.
- ▶ Do not stand under suspended loads.
- ▶ Keep a sufficient distance from the load during the lifting process.
- ▶ Observe local laws and regulations concerning the lifting of loads.

⚠ ATTENTION Risk of damage to the product, the facade and/or the roof due to improper assembly!

- ▶ Only use the fastening elements supplied (e.g. foot plates) or a foundation specified by the manufacturer (e.g. sleeve foundation).
- ▶ Always carry out assembly in accordance with the statics specifications or the regulations specified in the chart.
- ▶ Never change the assembly method. Follow the instructions in the assembly manual.

⚠ ATTENTION Risk of damage to the product due to improper unpacking!

- ▶ Do not use sharp objects to open the packaging.

3 Transport & storage



⚠ CAUTION Risk of injury from lifting heavy loads!

- ▶ The individual elements of the product must always be lifted by at least two persons or by means of a mechanical lifting aid.
- ▶ Do not stand under suspended loads.
- ▶ Keep a sufficient distance from the load during the lifting process.
- ▶ Observe local laws and regulations concerning the lifting of loads.

⚠ ATTENTION Risk of damage to the product due to improper storage!

- ▶ Store the product only in a dry and well-ventilated room.
- ▶ Protect from moisture, dust and dirt during storage.
- ▶ Remove and replace damp packaging immediately.
- ▶ Do not store any other objects on top of the packed product.

4 Main components and profiles

Components

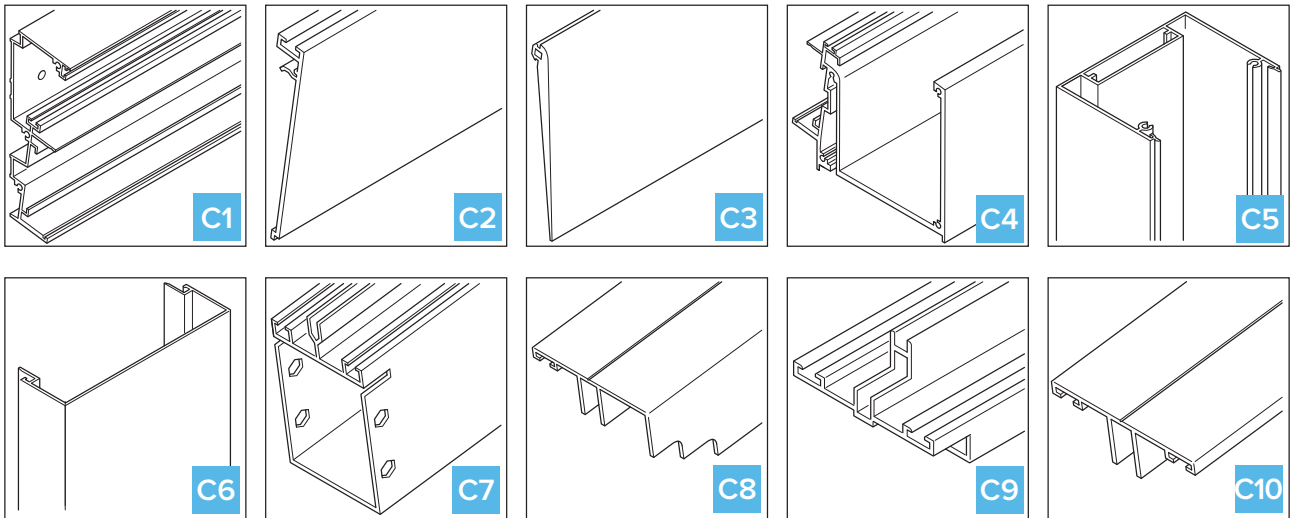

Accessories

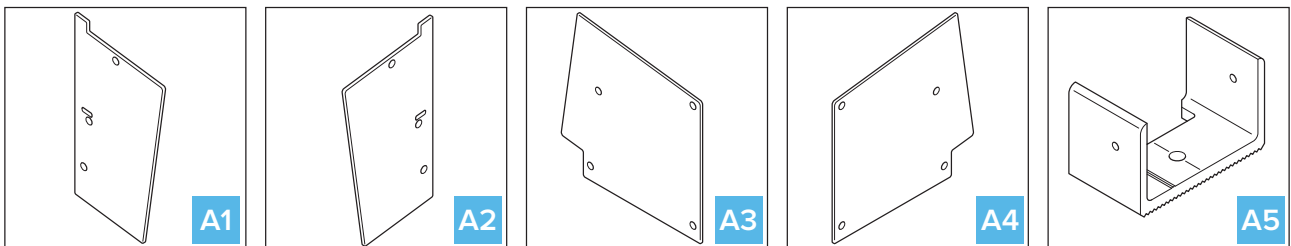

Fasteners

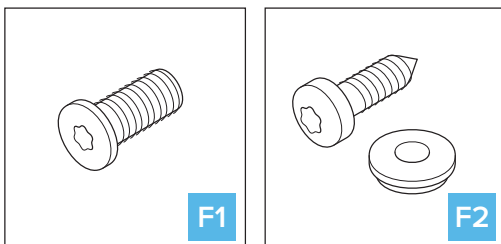

* Components C9 and C10 are included only in roof models with glass panels and a depth greater than 9'-10"

Roof Structure - Part Number Guide

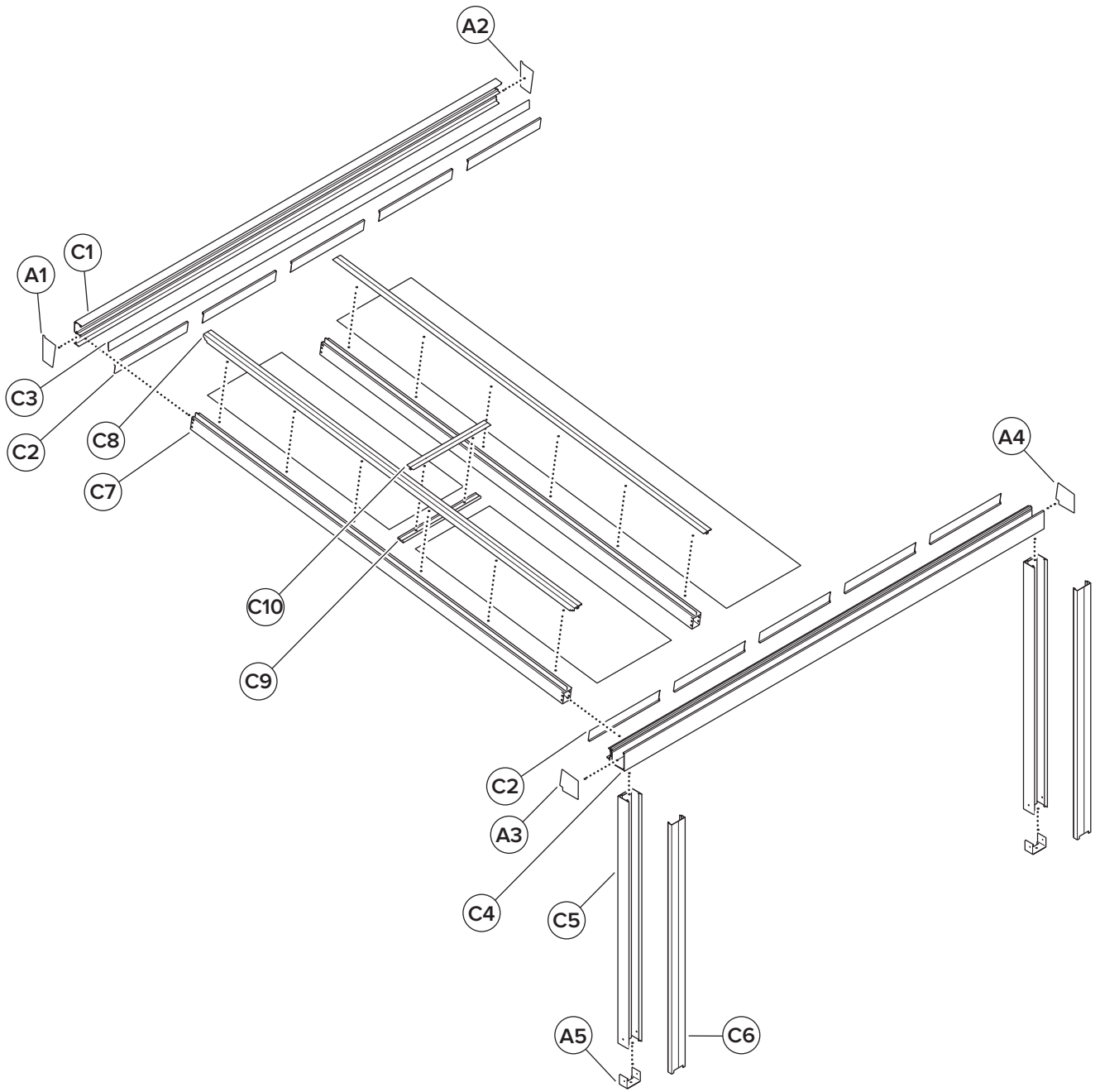

A Components C9 and C10 are included only in roof models with glass panels and a depth greater than 9'-10"

5 Preparations for assembly

5.1 Tools required for assembly

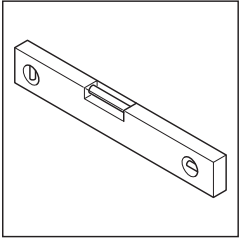

Spirit Level

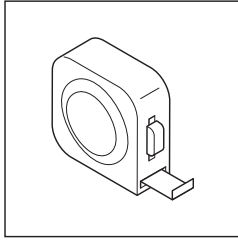

Tape Measure

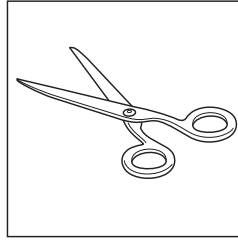

Scissors

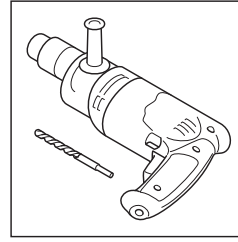

Impact drill

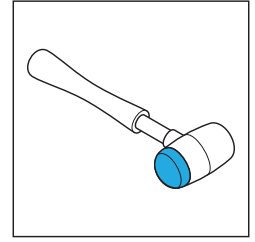

Plastic mallet

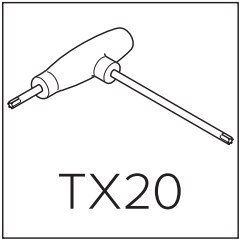

Torx driver Tx20

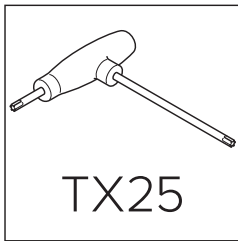

Torx driver Tx25

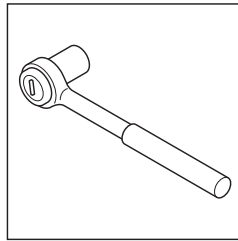

Ratchet wrench

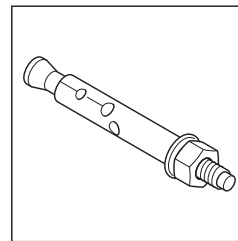

Steel dowel

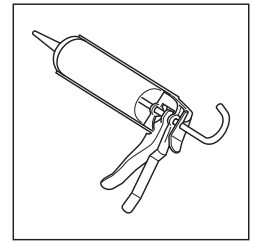

Silicone + Caulk gun

OPTIONAL

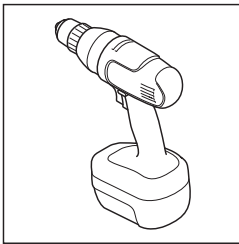

Electric screwdriver
Tx20 and Tx25 bits

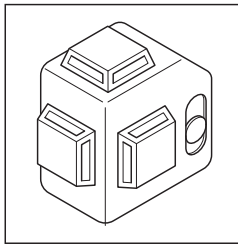

Laser Leveler

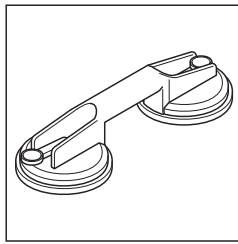

Glass suction cups*

* Necessary only for installations with glass panels.

5.2 Personal Protective Equipment (PPE) required for assembly



Wear protective clothing



Wear safety goggles



Wear hand protection



Wear a safety helmet



Wear safety shoes



Use a safety harness

6 Installation steps

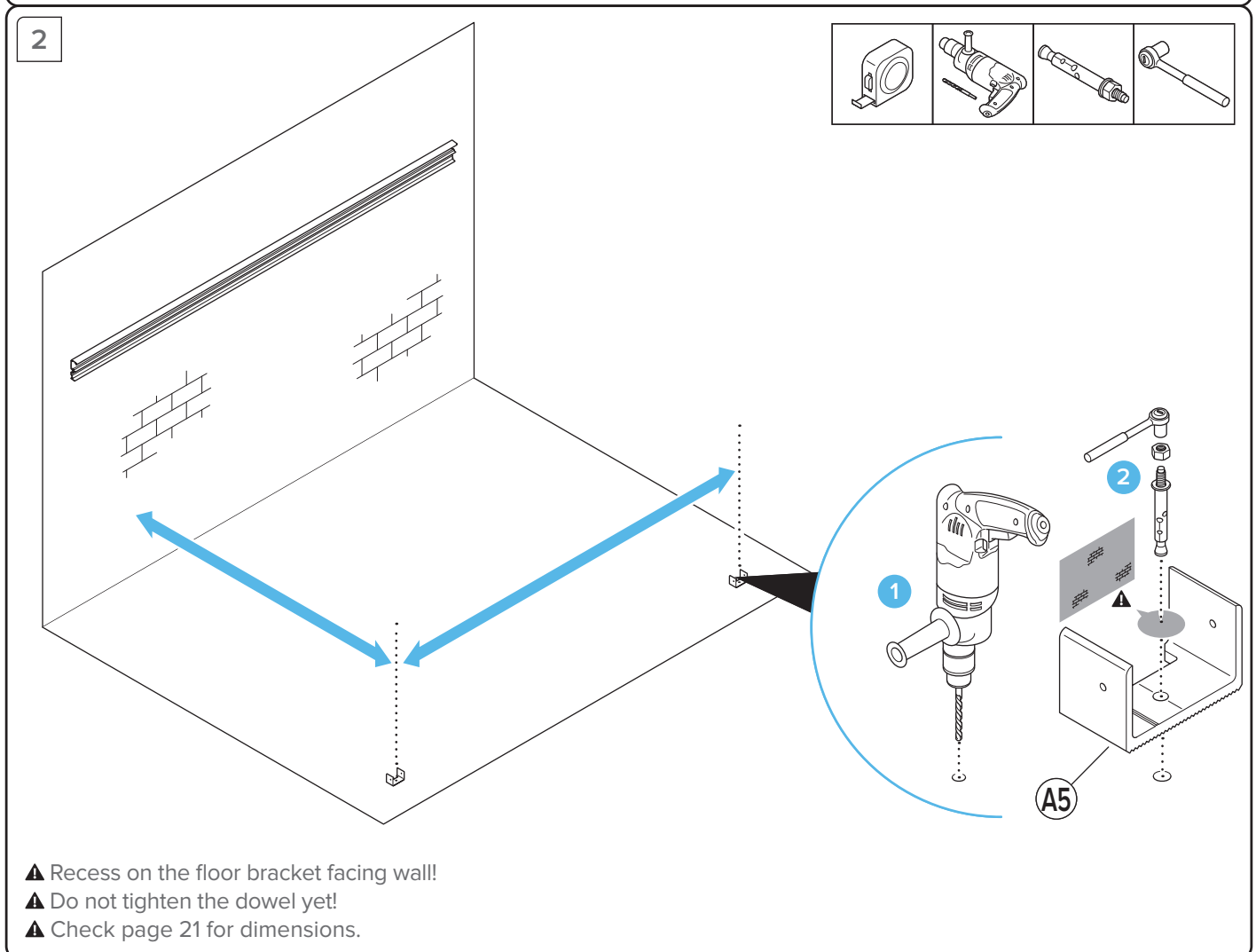
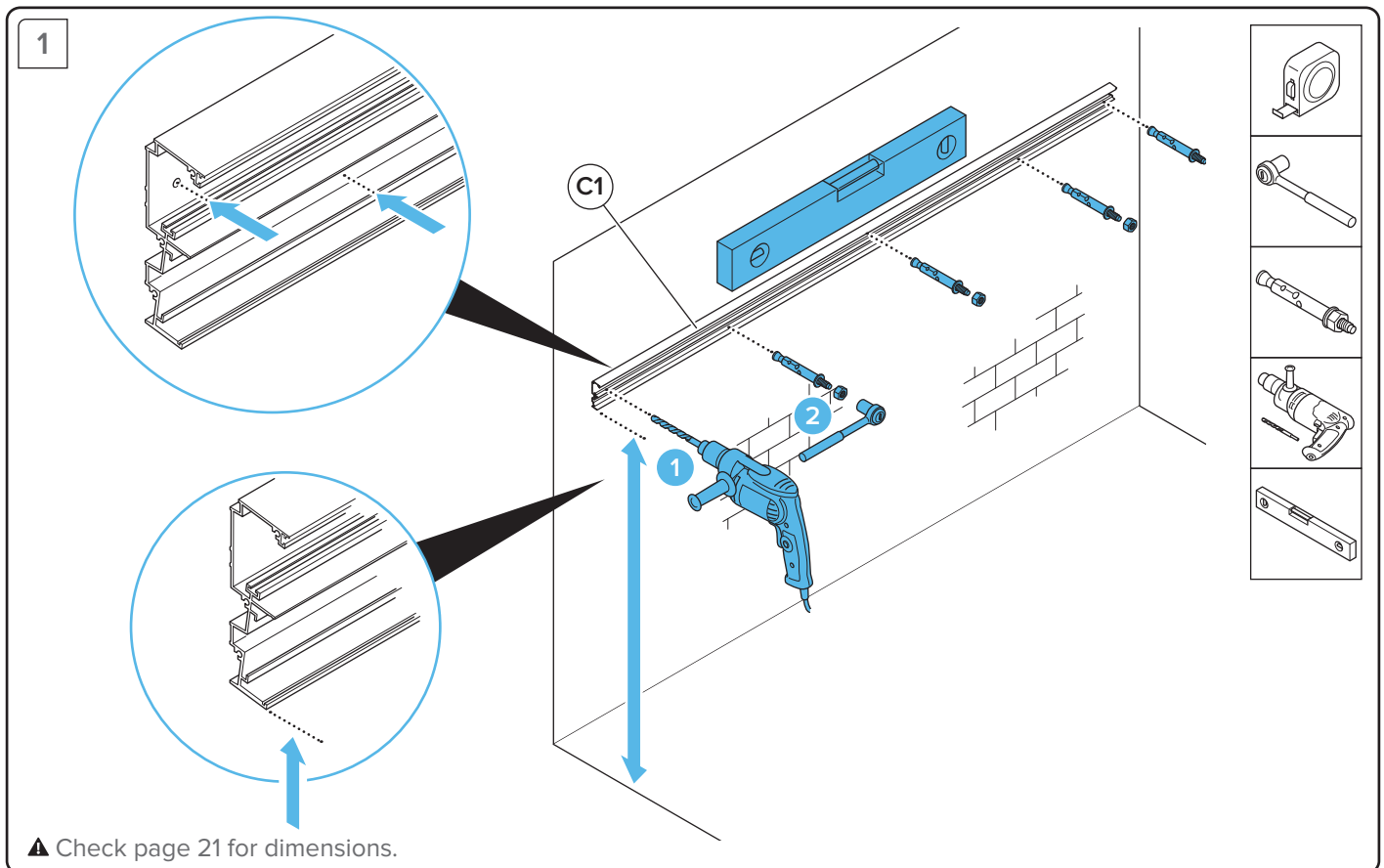

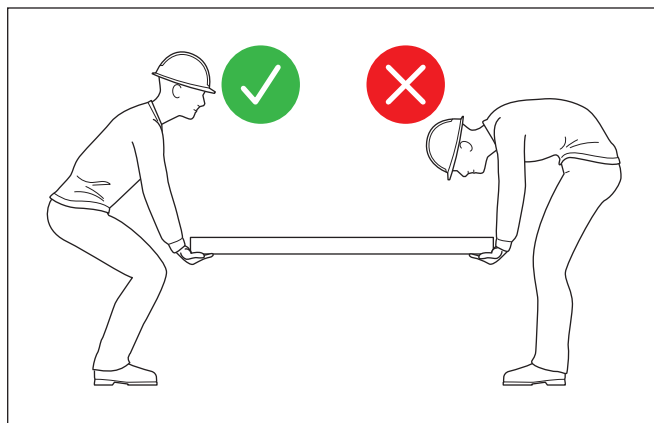
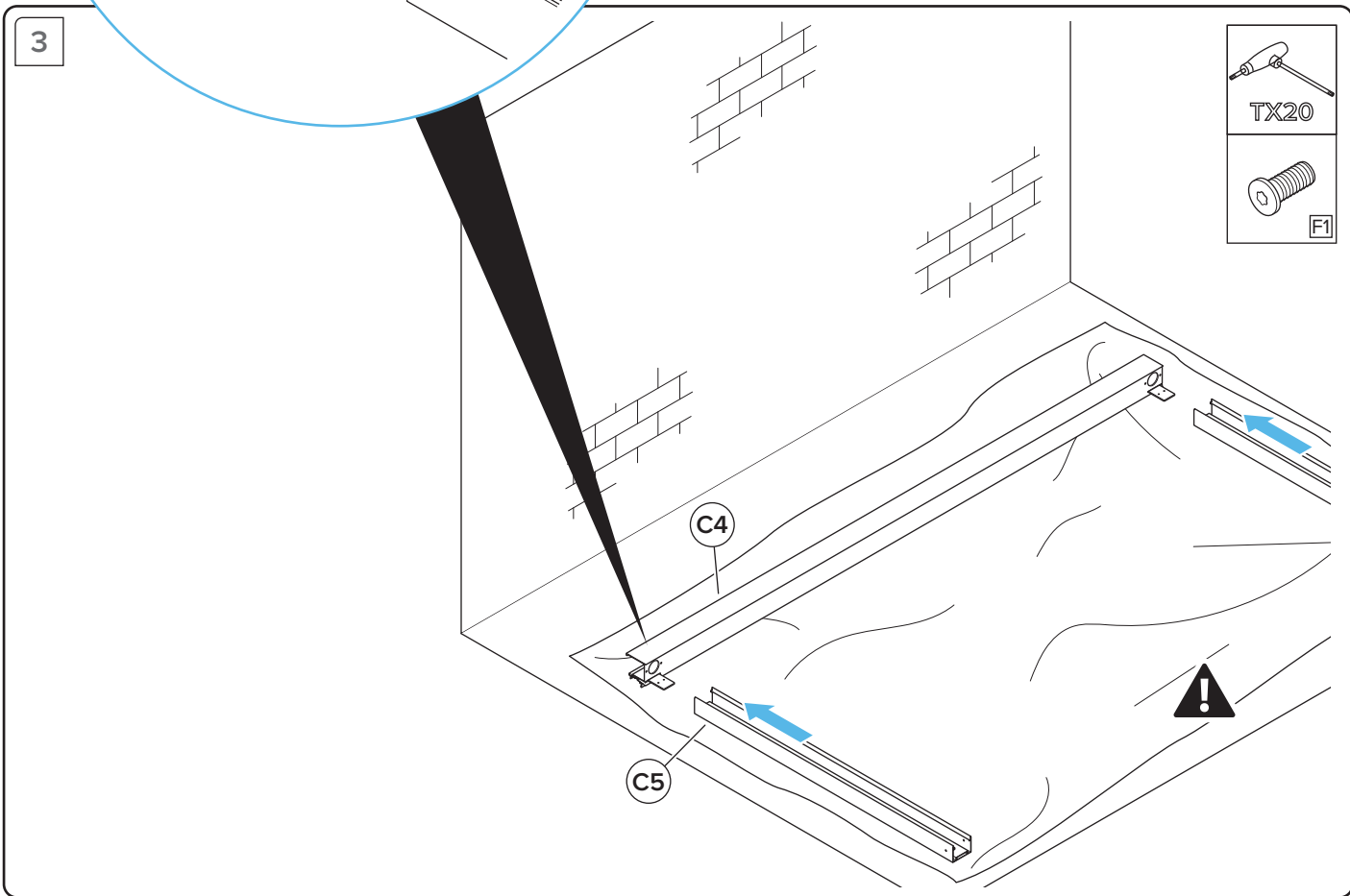
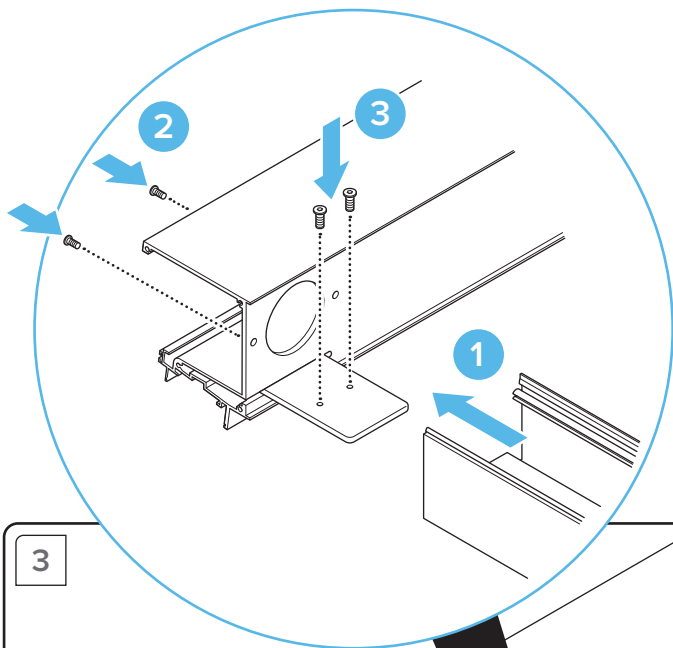

4

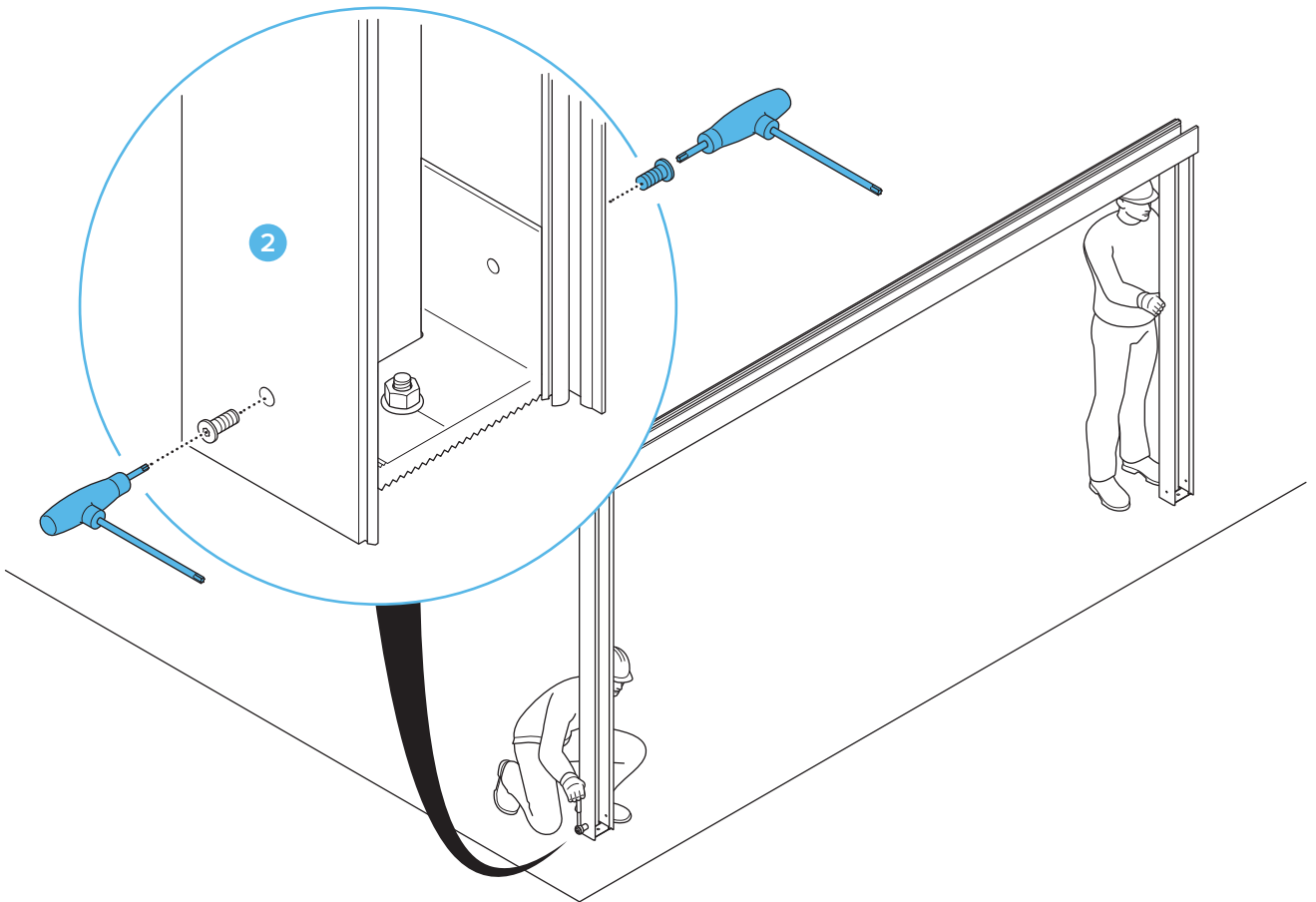
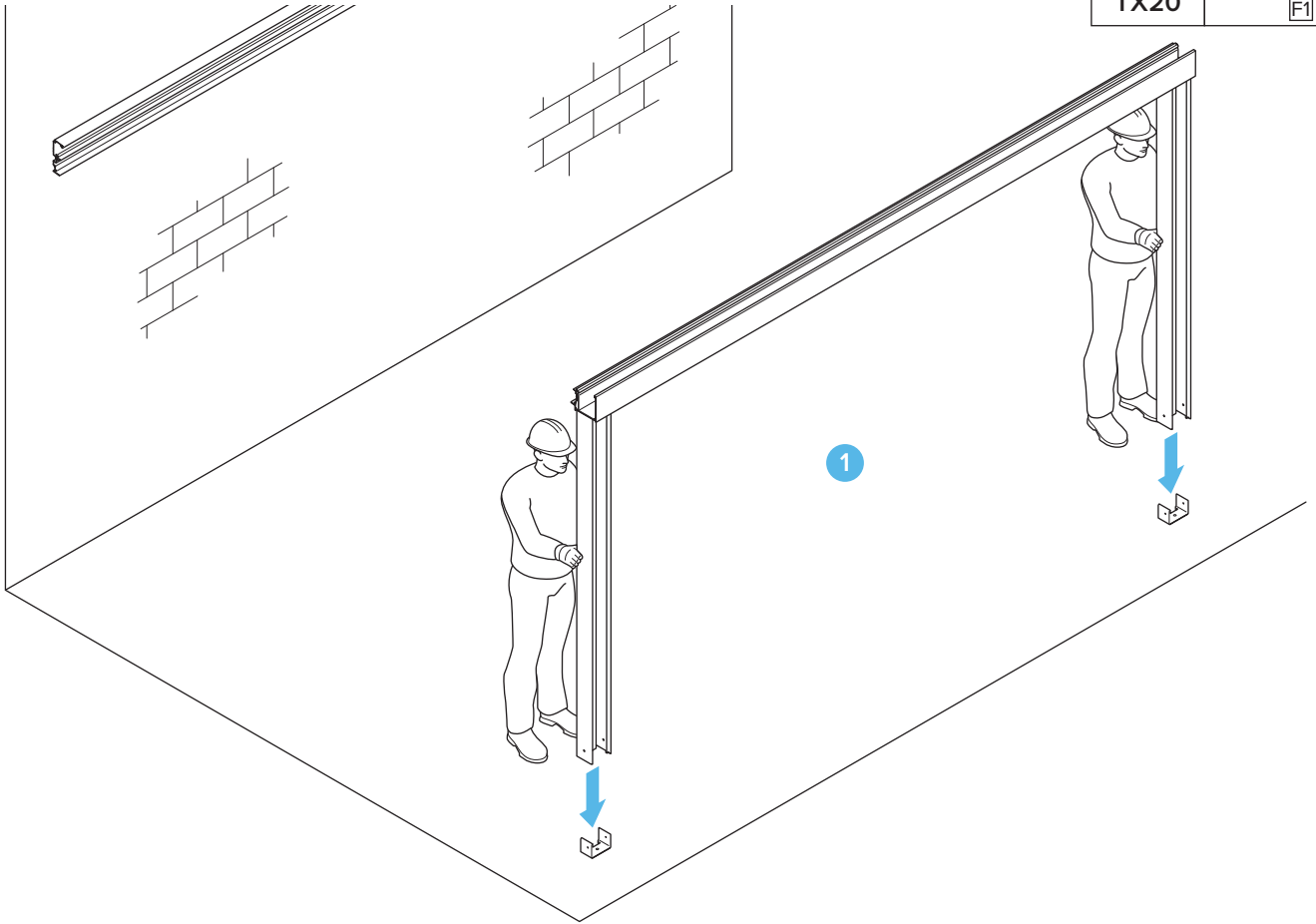
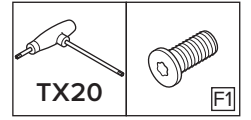

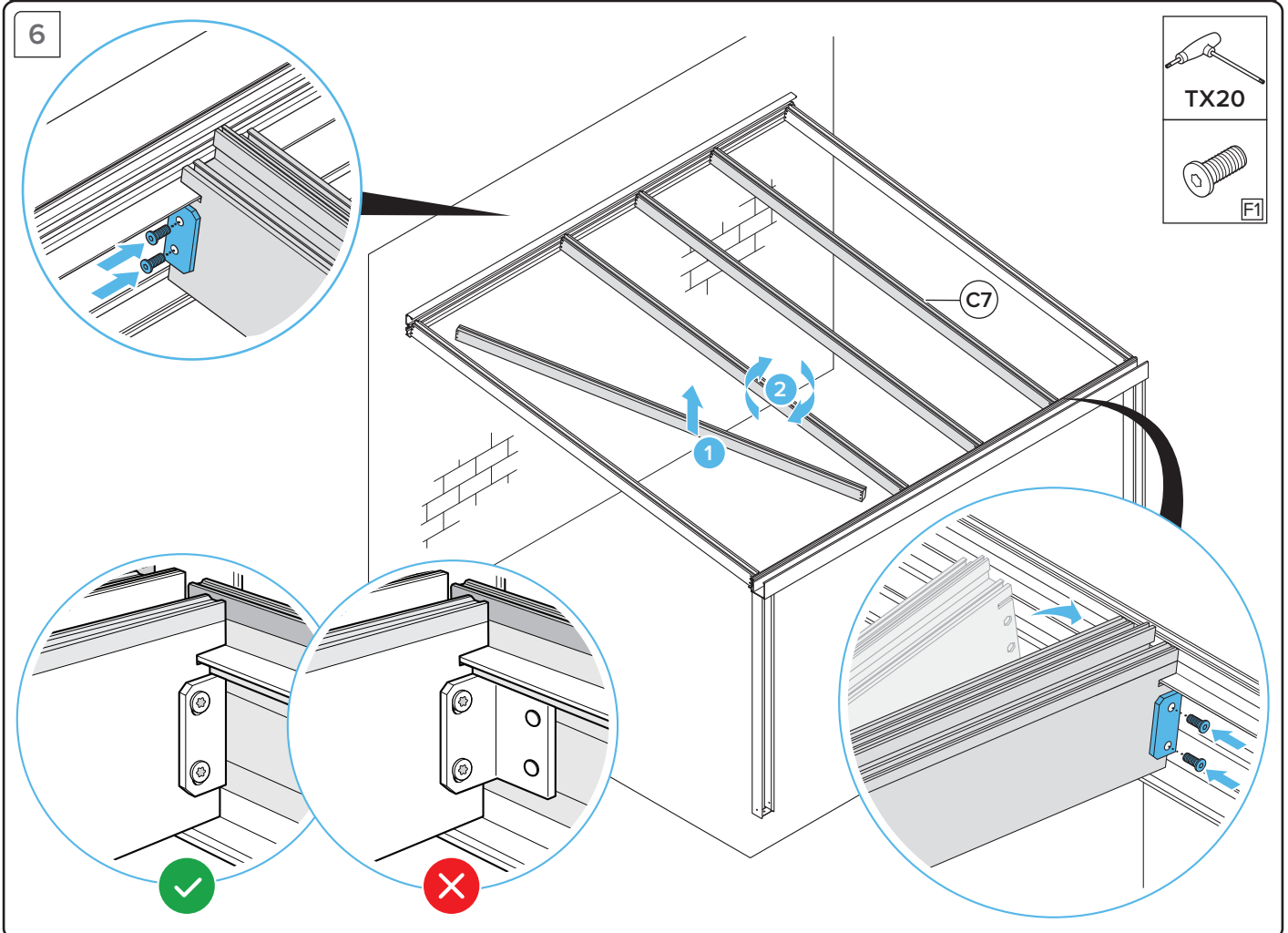
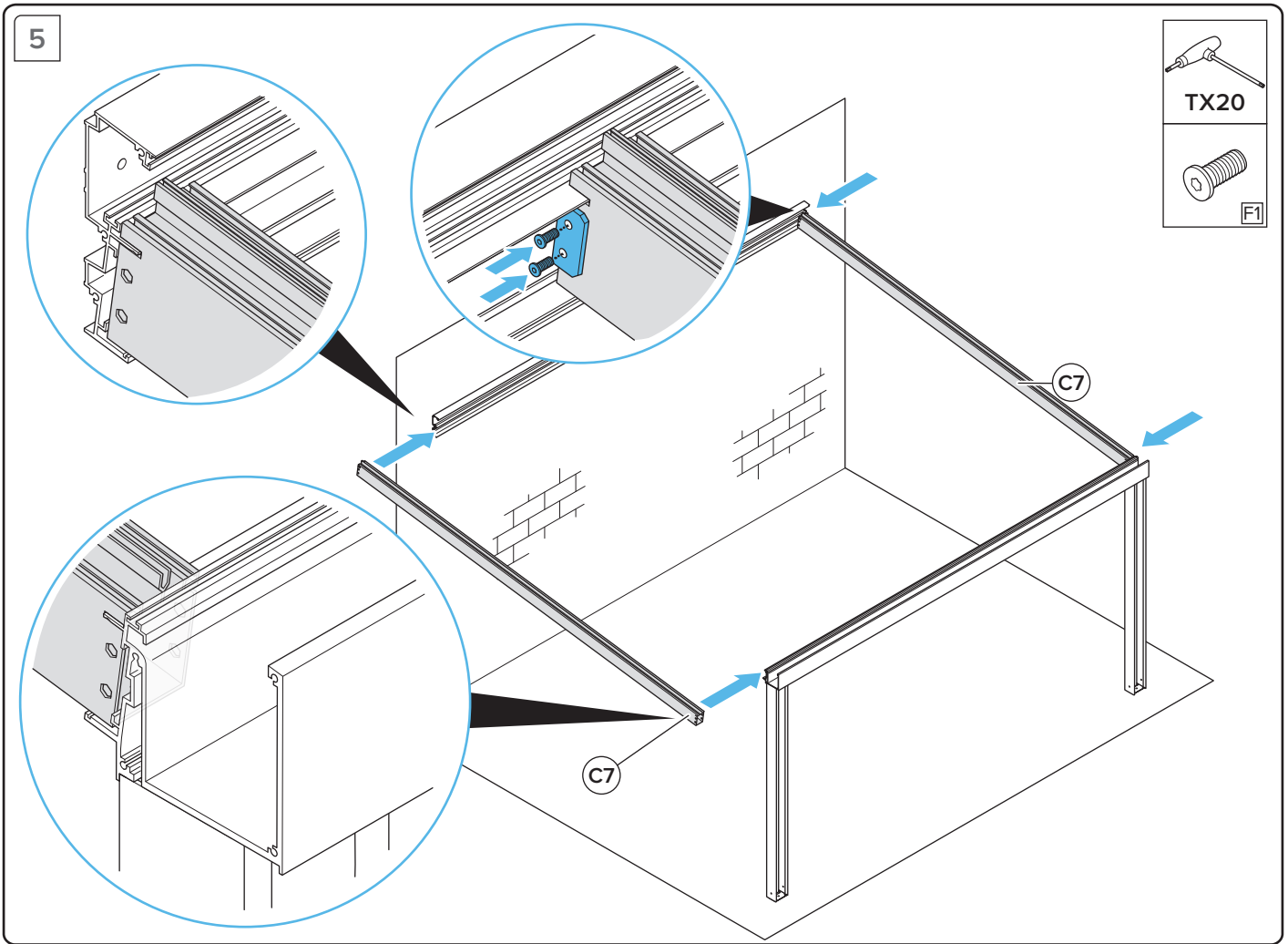

7

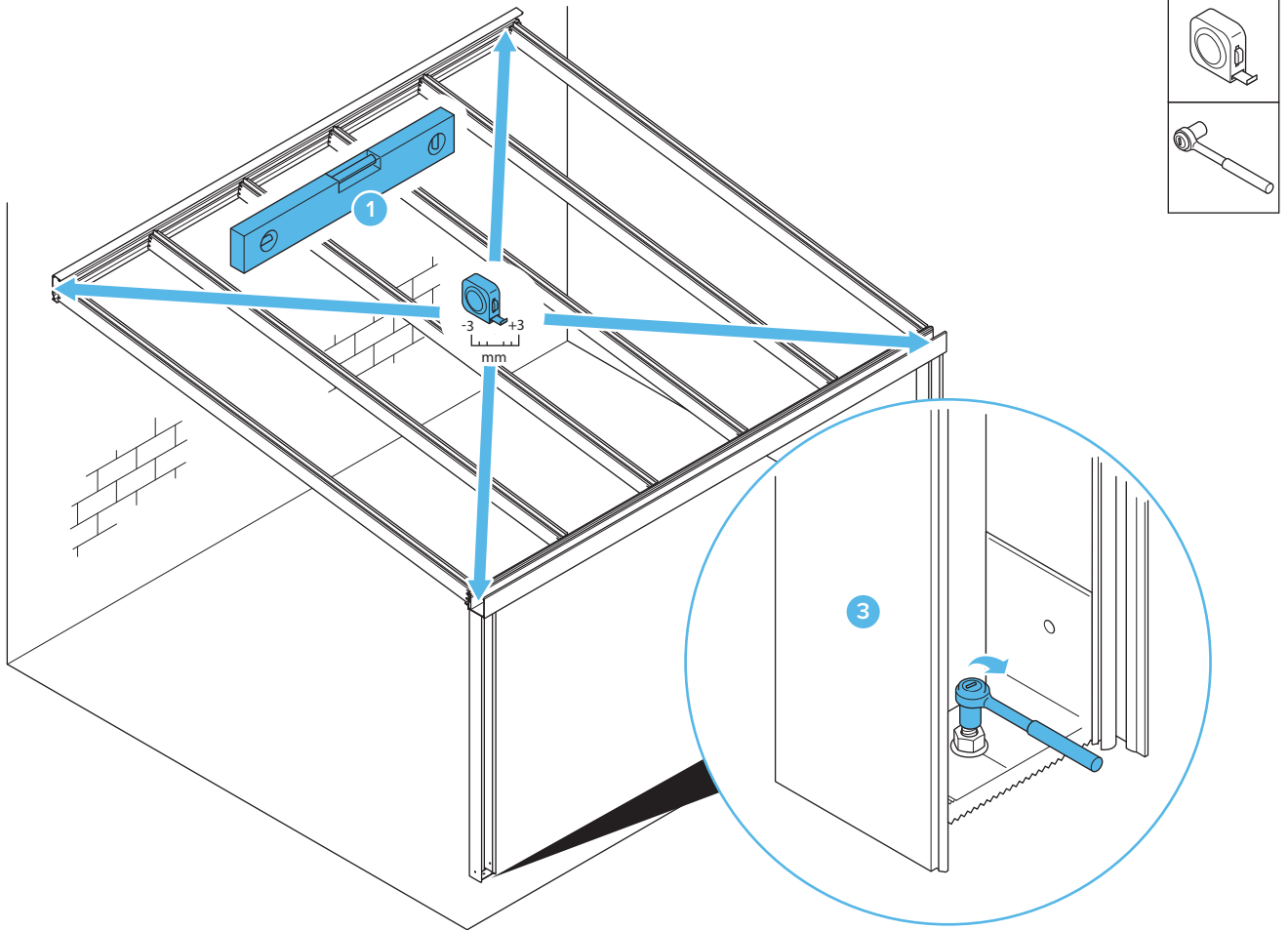

8

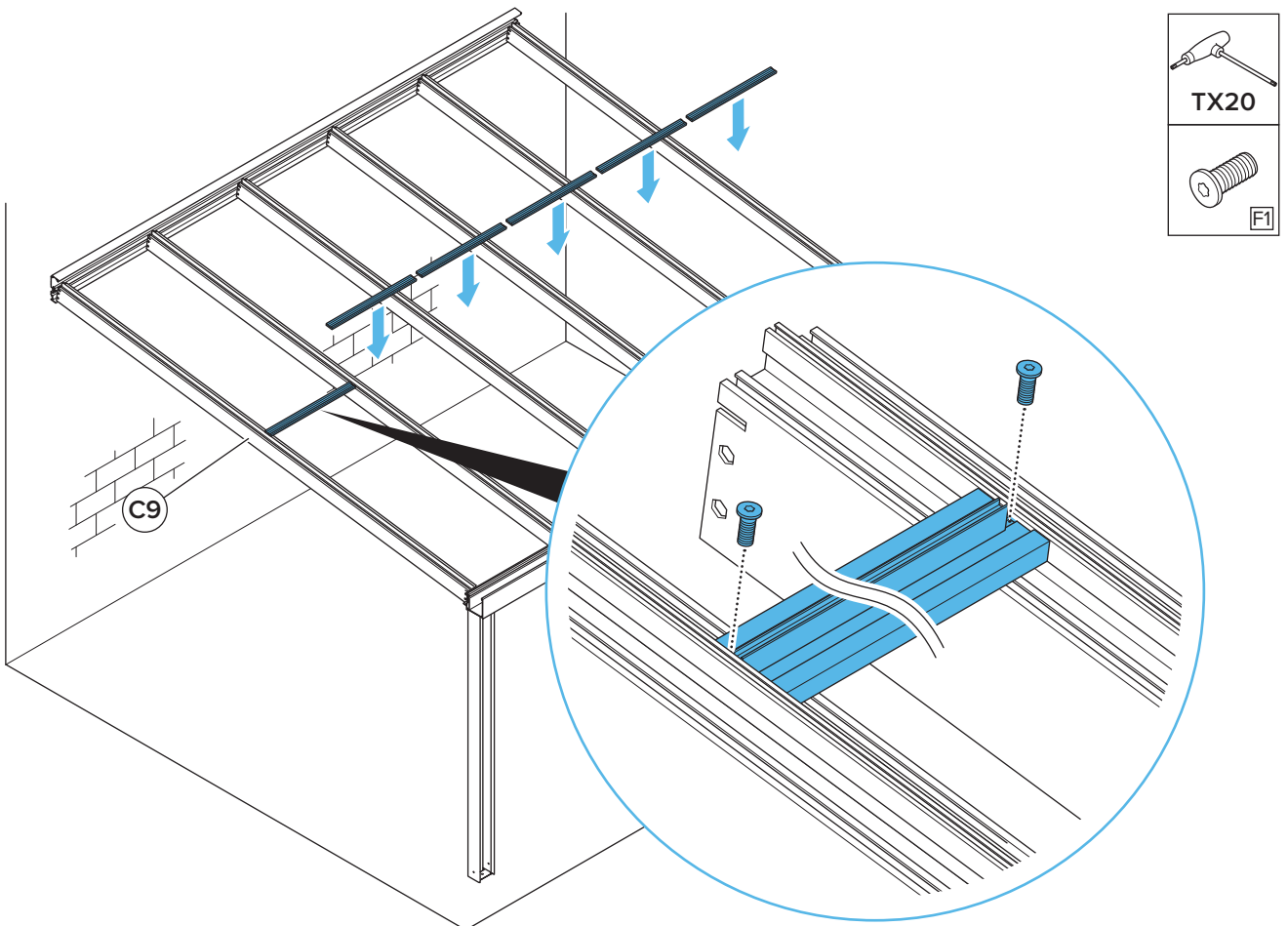

▲ Assembly of the components C9 and C10 is only mandatory for glass-panelled roof models with a depth exceeding 9'-10"

9

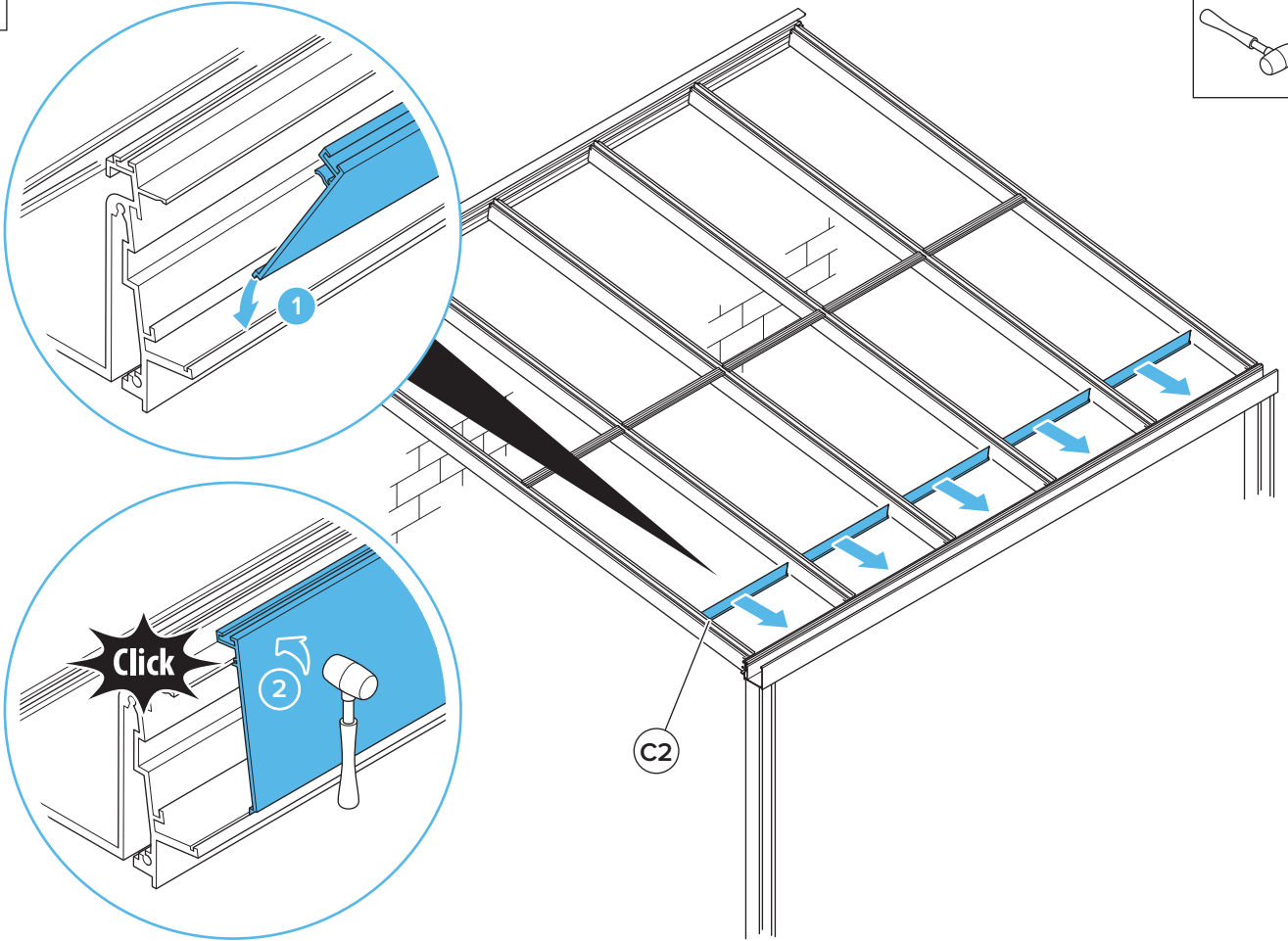
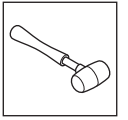

10

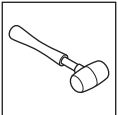
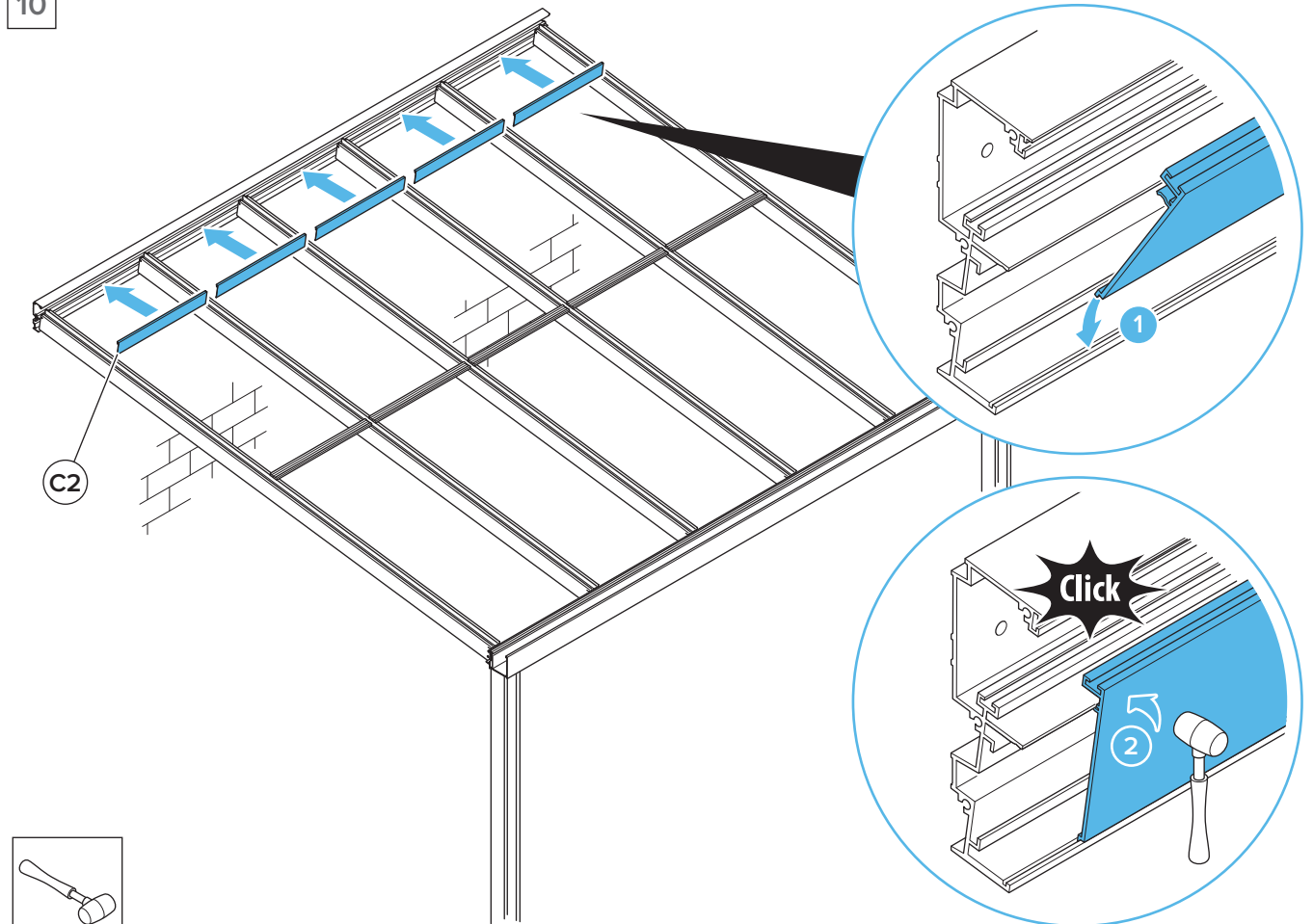

11

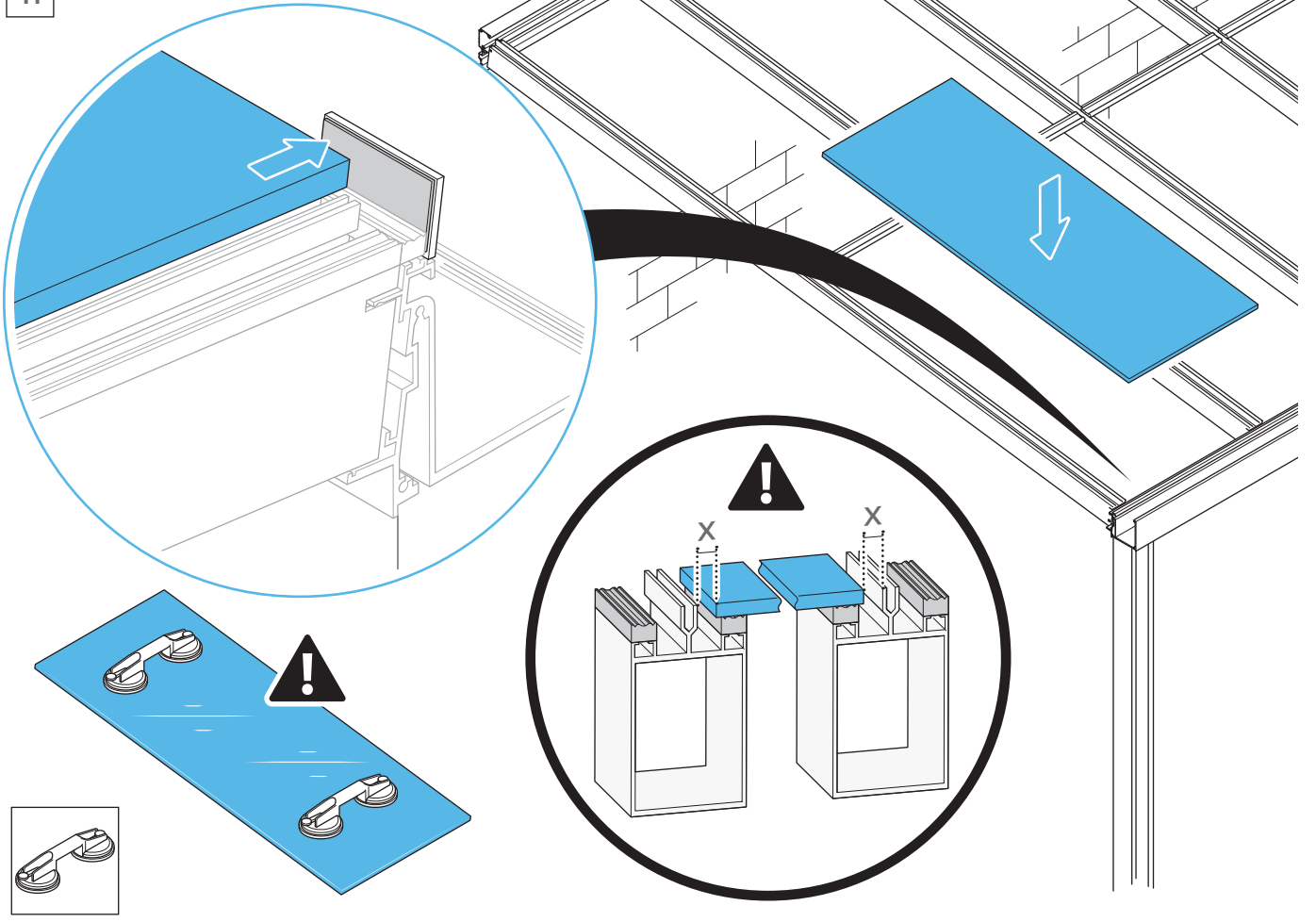

12

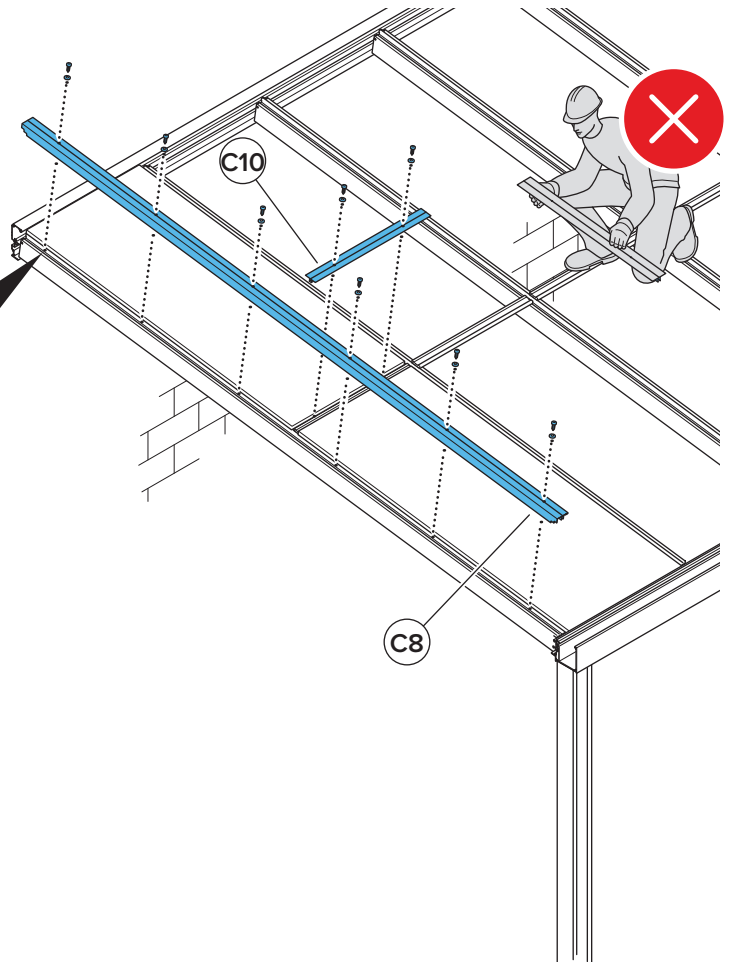
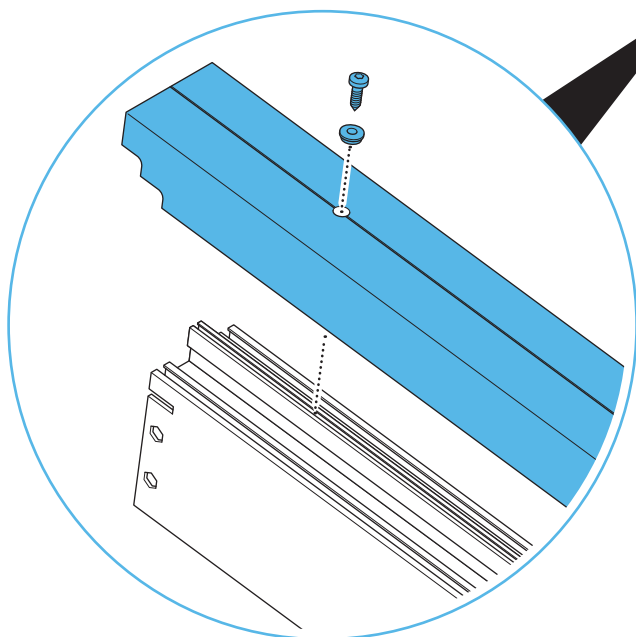
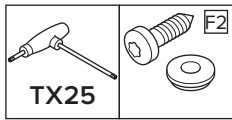

▲ Assembly of the components C9 and C10 is only mandatory for glass-panelled roof models with a depth exceeding 9'-10"

13

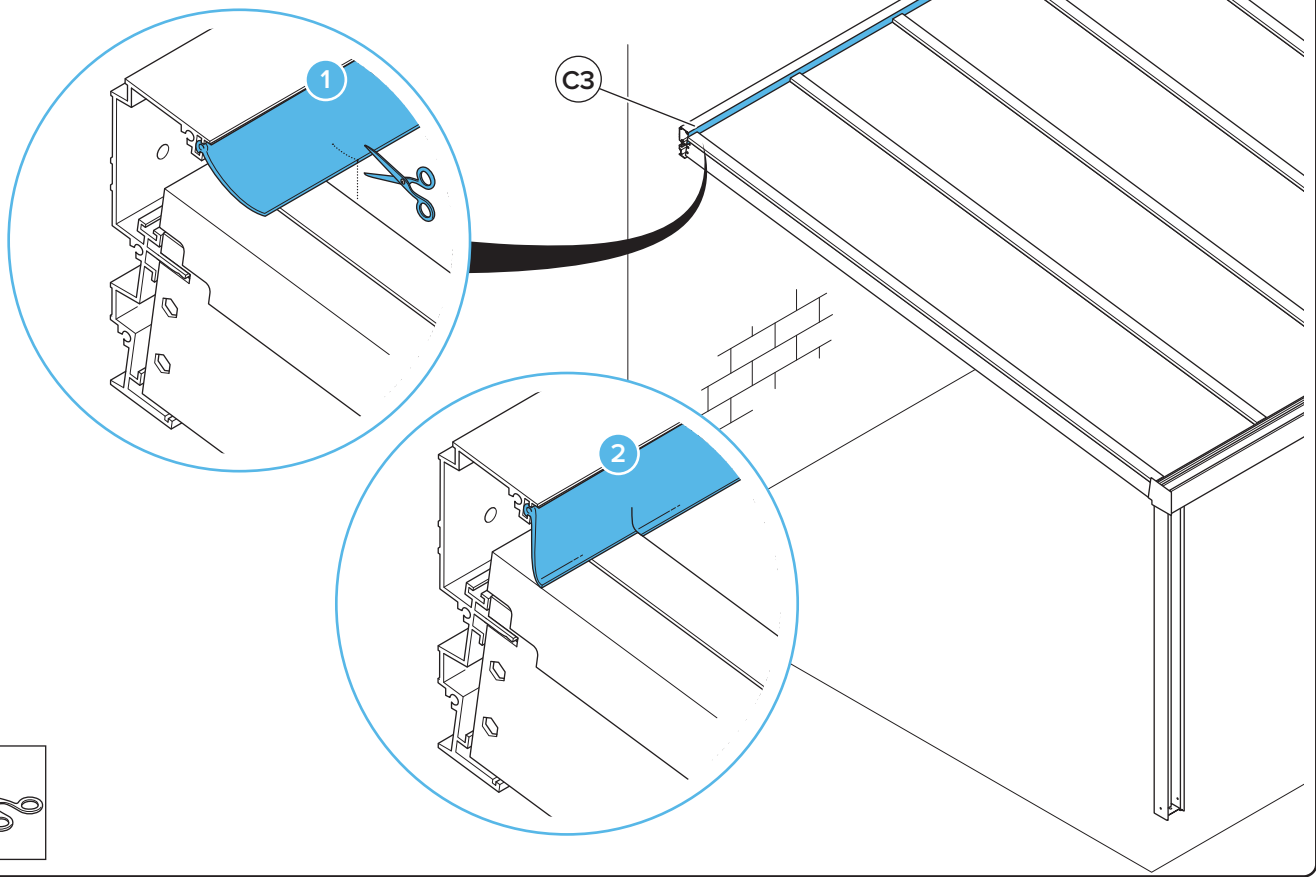

14

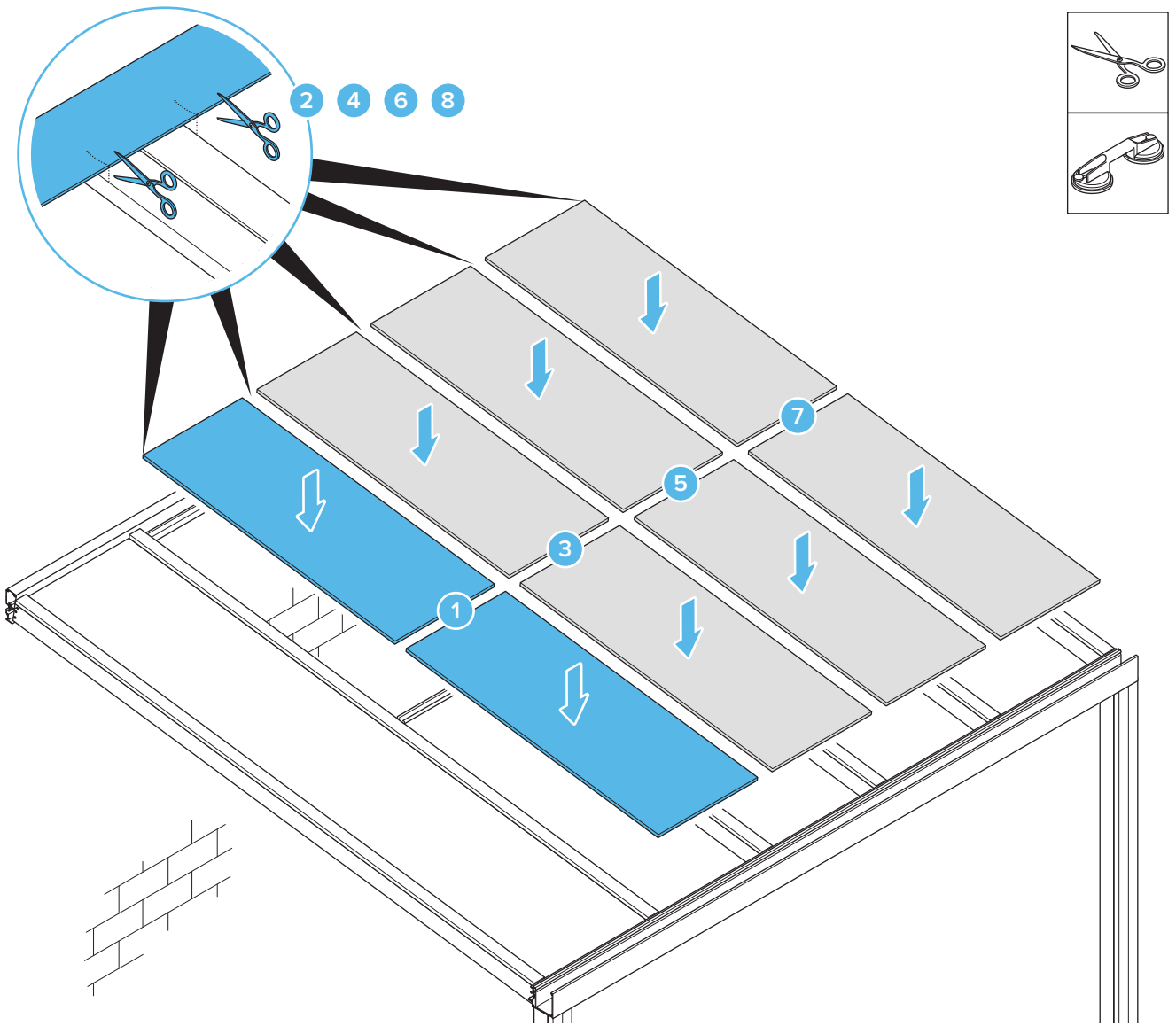

15

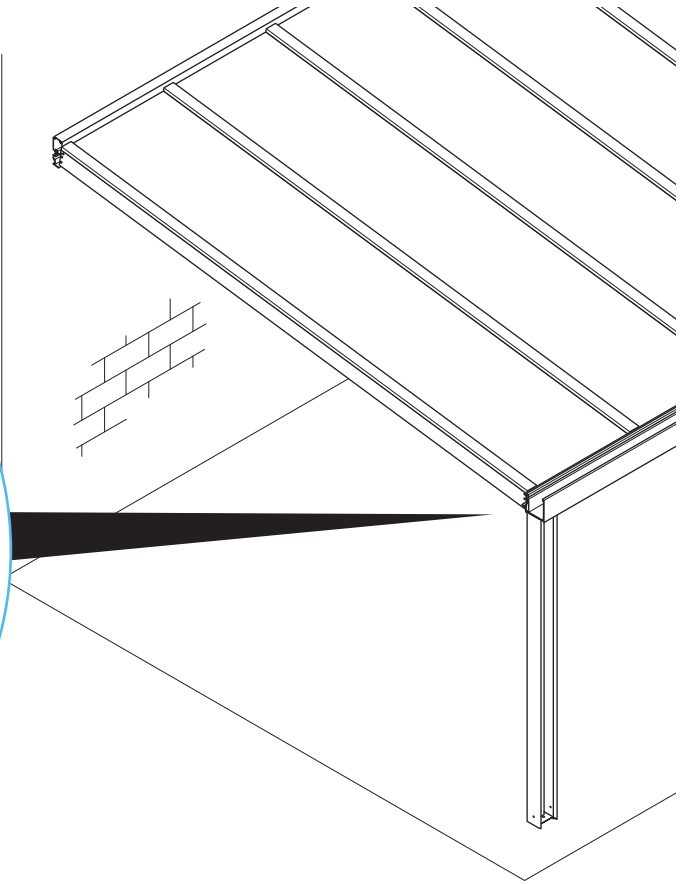
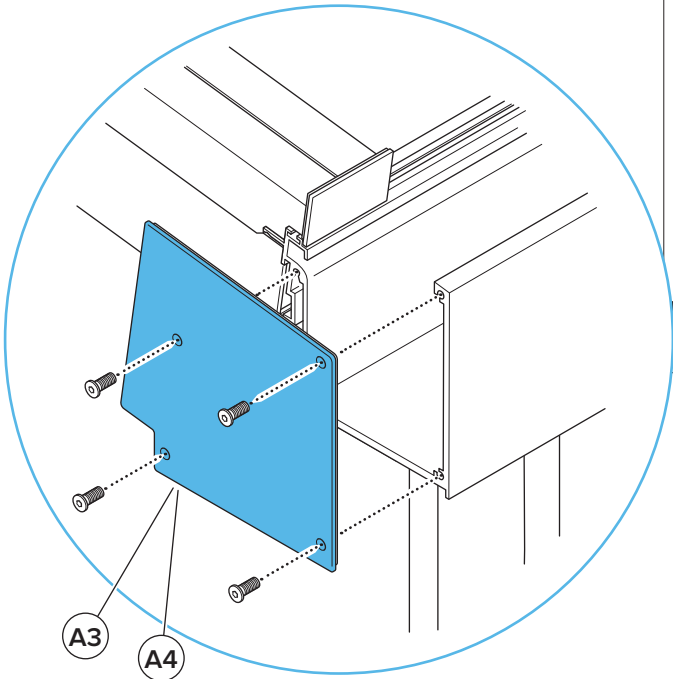
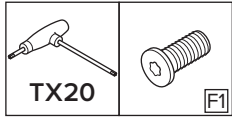

16

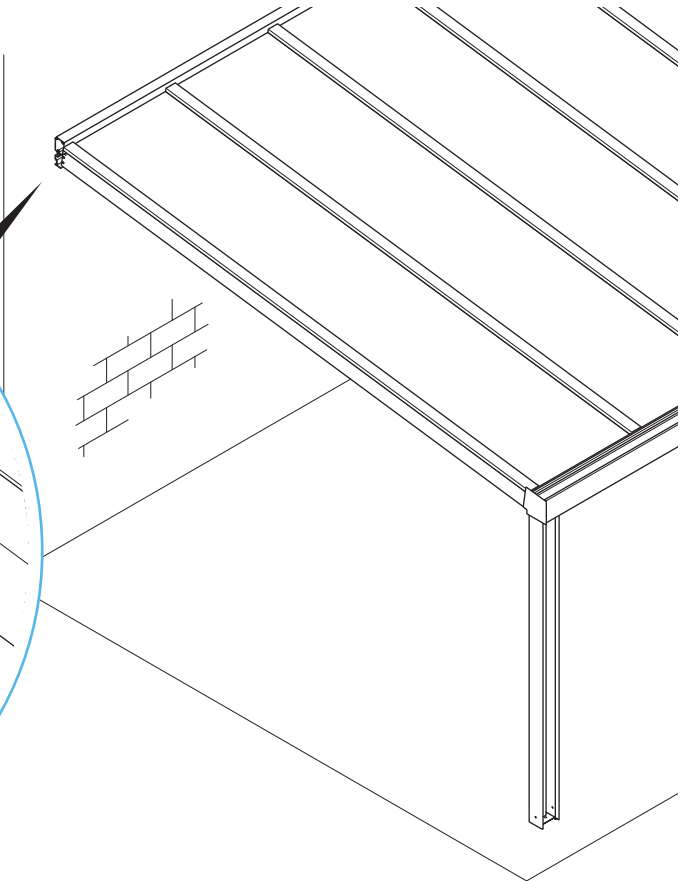
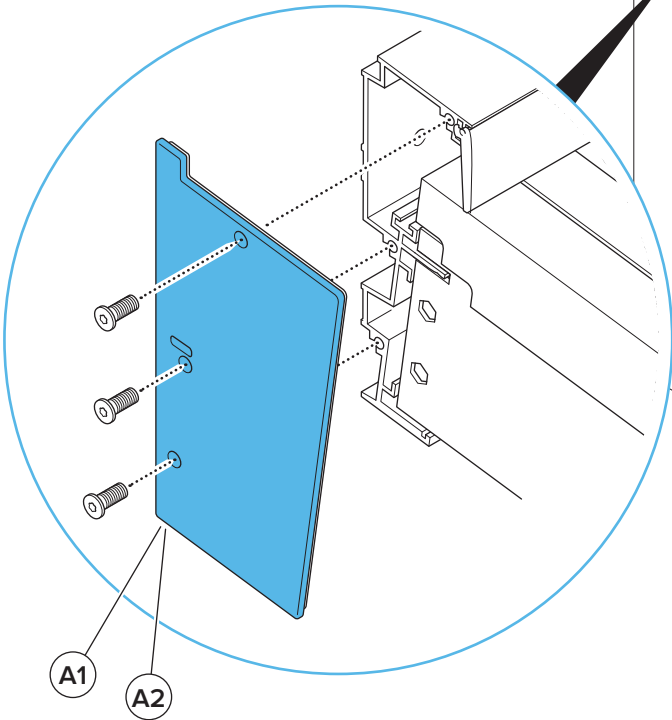
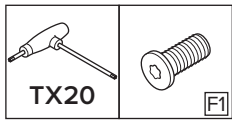

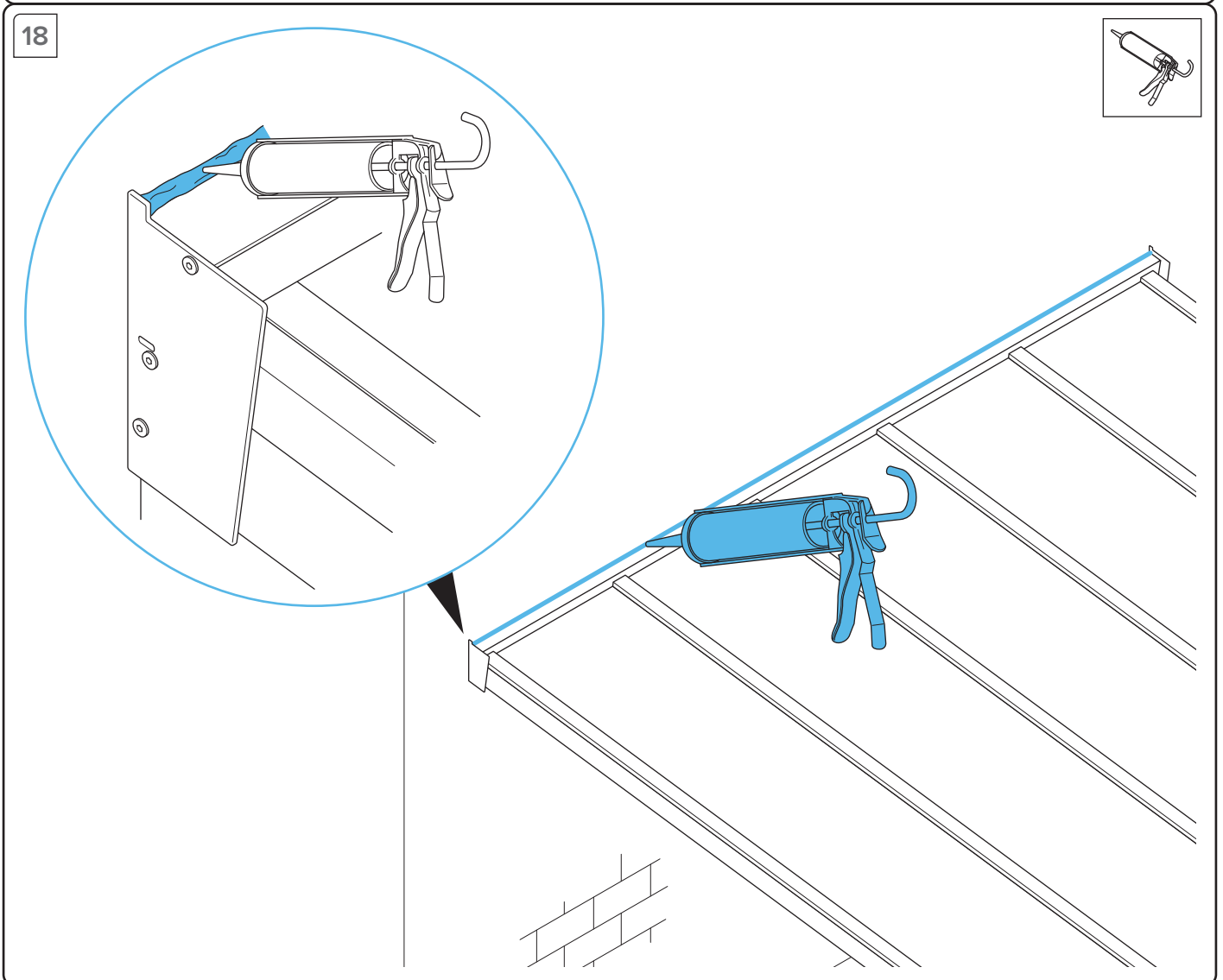
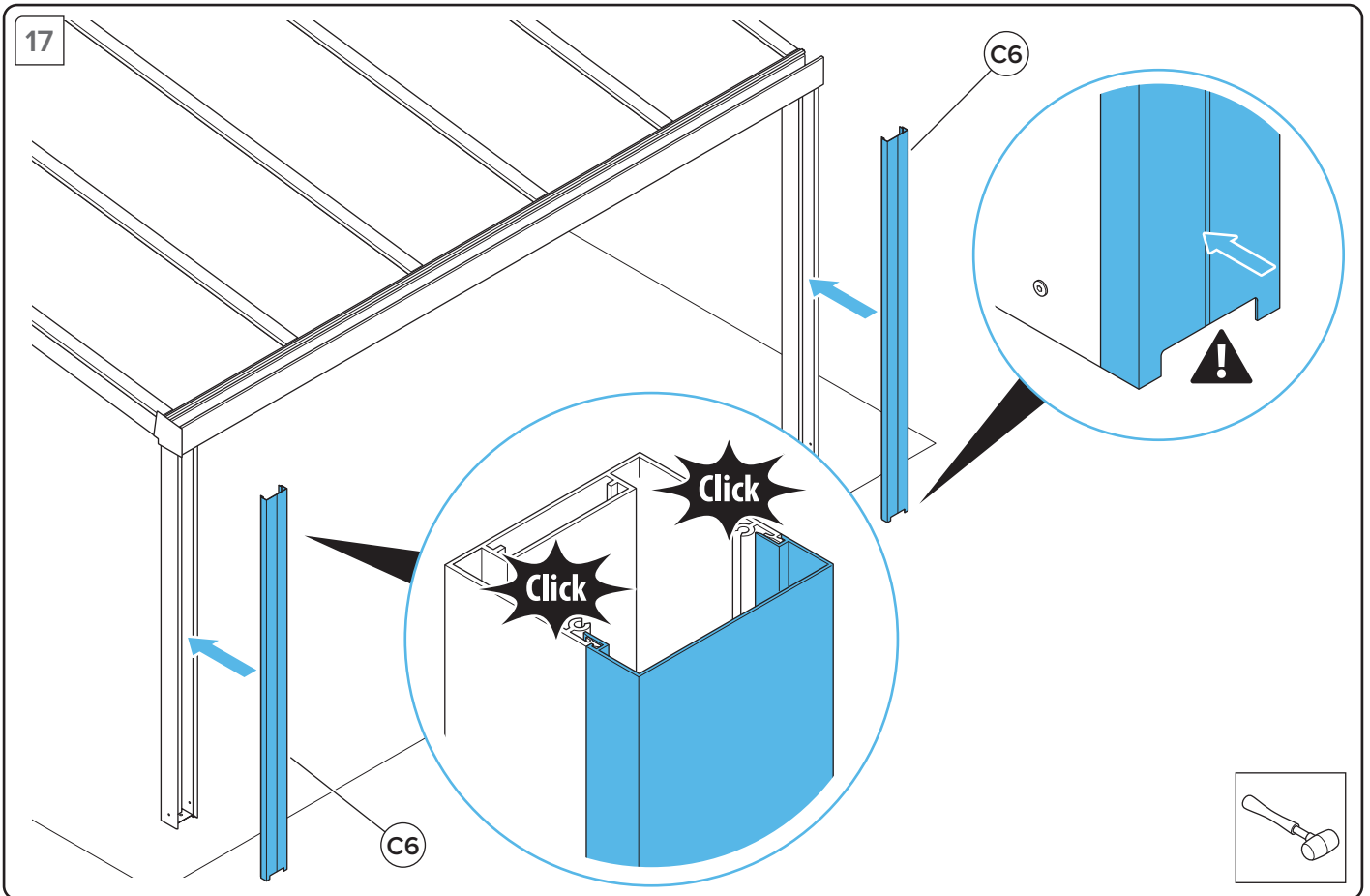

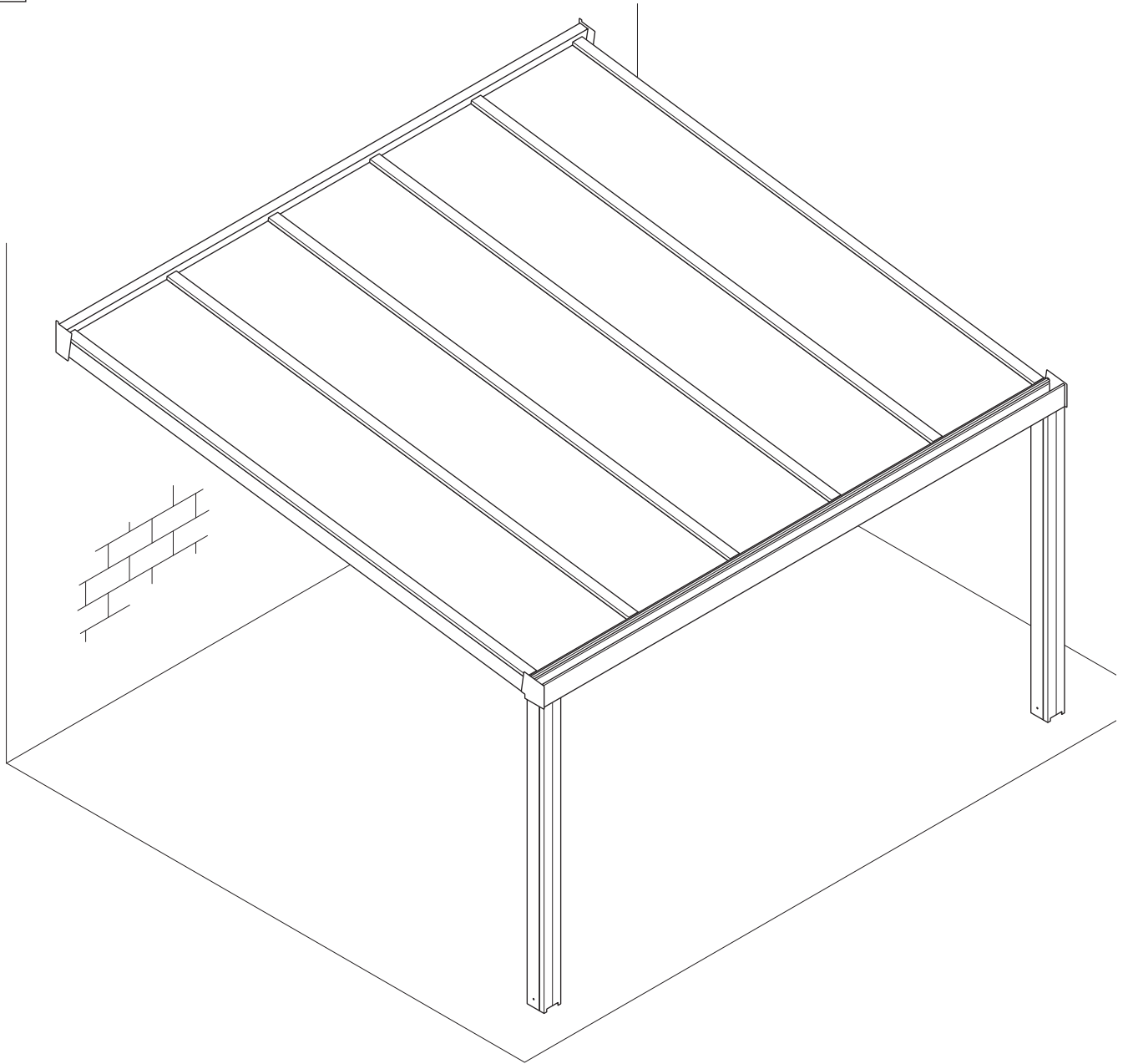

7 Dimensions

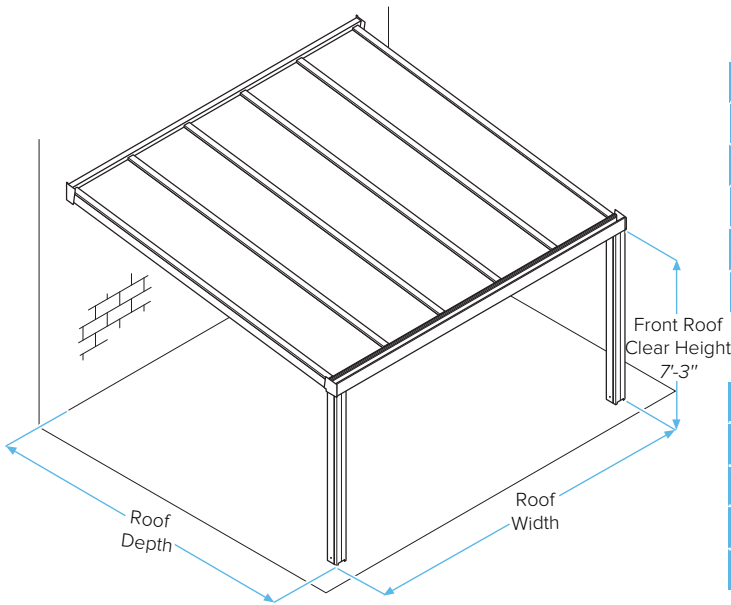

Front Roof Clear Height	7'-3"				
Roof Depth	6'-7"	8'-3"	9'-10"	11'-6"	
Wall Profile Bottom Height	D	8'-2"	8'-4 1/2"	8'-7 1/4"	8'-10"
Wall Fixation Hole Height 1	E	8'-3 1/2"	8'-6 1/4"	8'-9"	9'
Wall Fixation Hole Height 2	F	8'-6"	8'-8 3/4"	8'-11 5/8"	9'-2 1/4"
Floor Fixation Hole Depth	B	6'-3 1/2"	7'-11 1/4"	9'-7"	11'-2 5/8"

Roof Width	6'-7"	8'-3"	9'-10"	11'-6"	13'-1"	
Rafter Quantity	4	5	5	6	6	
Wall fixation hole distance 1	A	25 3/8"	23 31/32"	28 57/64"	27 3/64"	31"
Wall fixation hole distance 2	A/2	12 23/32"	12 16/4"	14 29/64"	13 35/64"	15 33/64"
Floor Fixation Hole Width	C	6'-1 5/8"	7'-9"	9'-5"	11"	12'-8 5/8"

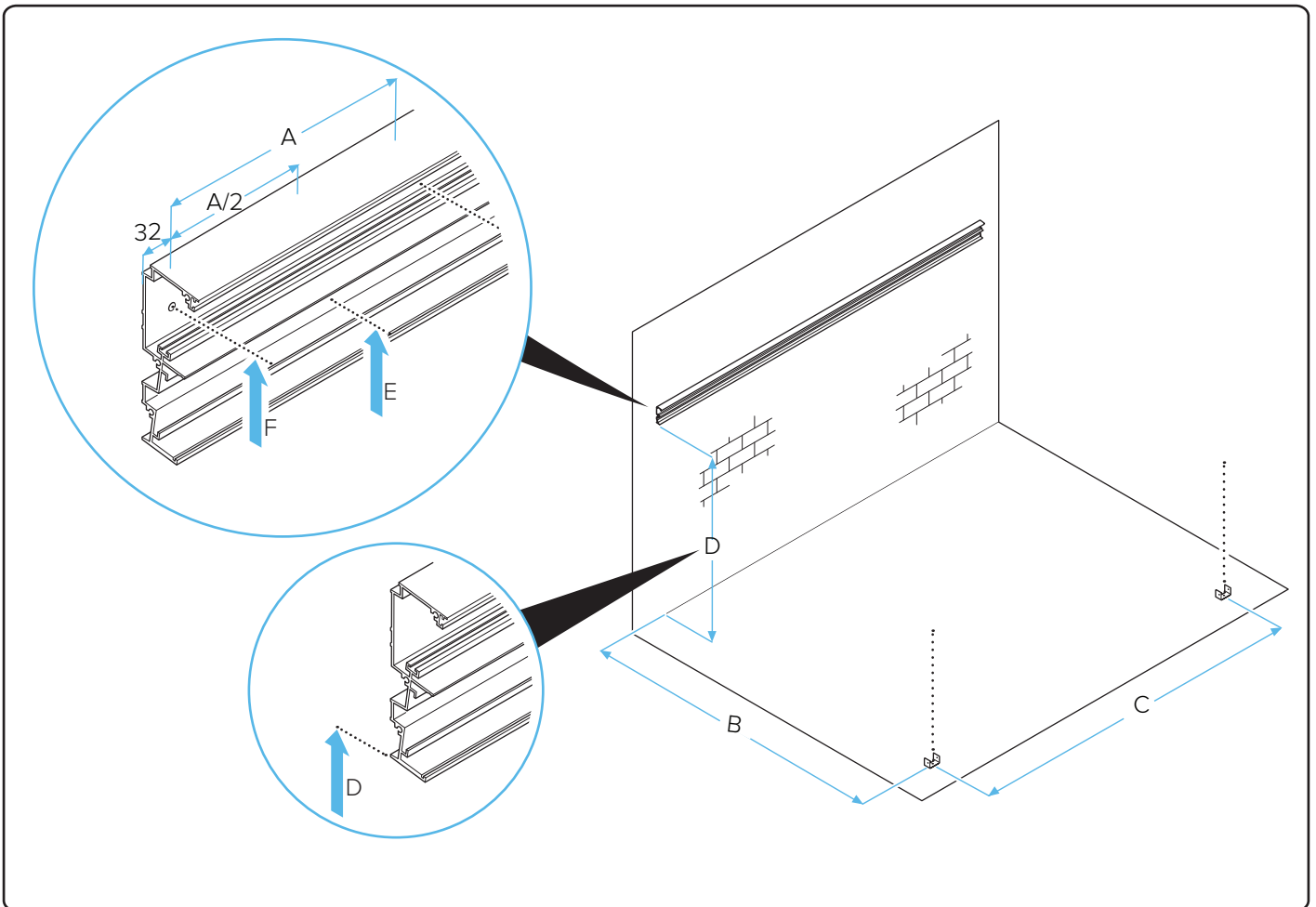
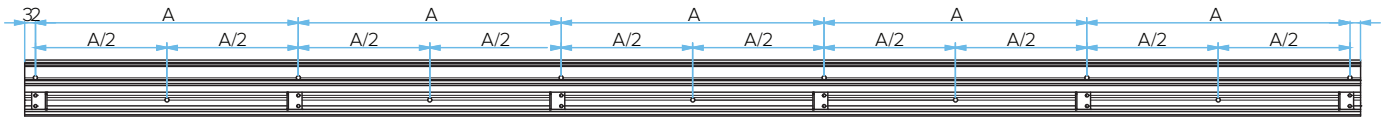

8 Cleaning and care

ATTENTION Risk of damage to the product due to improper cleaning!

Maintaining and caring for an aluminum, glass and polycarbonate roof requires specific steps to ensure longevity and performance. Clean the profiles and glazing regularly for every 6 months. The more aggressive the surrounding atmosphere, the more frequently cleaning must be carried out.

For Aluminum Parts:

1. Regular Cleaning:

- Use a mild detergent and water solution.
- Gently scrub with a soft-bristle brush or cloth to avoid scratching the surface.
- Rinse thoroughly with water.

2. Removing Stains and Mildew:

- For tougher stains, use a cleaner specifically designed for aluminum.
- Apply a solution of one part vinegar to nine parts water for mildew removal.

3. Checking for Damage:

- Inspect for any dents, scratches, or corrosion.
- Repair minor damages promptly to prevent worsening.

4. Applying Protective Coating:

- Every few years, consider applying a protective sealant or coating to guard against oxidation and weathering.

5. Gutter Maintenance:

- Keep gutters and drains clear of debris to prevent water accumulation.

For Polycarbonate Roof:

1. Gentle Cleaning:

- Use a mild soap solution and a soft cloth or sponge.
- Avoid abrasive cleaners or brushes that can scratch the surface.

2. Rinsing:

- Rinse the roof with lukewarm water. Avoid high-pressure water jets which can damage the polycarbonate.

3. Removing Chemicals:

- Immediately clean off any chemicals or harsh solvents that come into contact with the polycarbonate to prevent damage.

4. Checking for Scratches and Damage:

- Regularly inspect for scratches or impact damage.
- Minor scratches can often be polished out, but larger damages may require panel replacement.

5. UV Protection:

- Ensure that the polycarbonate panels have UV protection. If not, consider applying a UV protective coating.

6. Avoiding Excessive Heat:

- Be cautious of placing heat sources too close to polycarbonate panels as they can warp under extreme heat.

For Glass Roof:

1. Regular Cleaning:

- Use a mixture of mild soap and water, or a glass cleaner.
- Apply with a non-abrasive sponge or a soft cloth to avoid scratching the glass.

2. Streak-Free Finishing:

- Use a squeegee or a clean, dry cloth to remove water and avoid streaks after washing.
- Vinegar mixed with water can be an effective solution for a streak-free finish.

3. Removing Tough Stains:

- For hard water stains or bird droppings, use a solution of vinegar and water.
- Apply the solution and let it sit for several minutes before gently wiping away.

4. Dealing with Condensation:

- Ensure adequate ventilation to reduce condensation buildup which can lead to mold and mildew.

5. Avoiding Abrasive Tools:

- Do not use scrapers, steel wool, or abrasive sponges as they can scratch the glass surface.

6. Snow and Ice Removal:

- If applicable, remove snow and ice gently to prevent scratching or cracking the glass.

7. Professional Cleaning for Hard-to-Reach Areas:

- For high or hard-to-reach areas, consider hiring a professional cleaning service to ensure safety and thorough cleaning.

9 Maintenance

- **Consistency in Cleaning:** Regular cleaning prevents the buildup of grime and dirt, which can be harder to clean if left for too long.
- **Safety First:** Use appropriate safety equipment and precautions when cleaning, especially for elevated or sloped glass roofs.
- **Avoid Strong Chemicals:** Harsh chemicals can damage the glazing or coatings on the glass. Always use gentle, non-abrasive cleaners.
- **Check Sealants and Flashing:** Ensure that the sealants and flashing around the glass panes are intact to prevent leaks.

By following these maintenance and care instructions, you can keep your aluminum, polycarbonate, and glass roofs in optimal condition, ensuring they provide both aesthetic appeal and functional protection for many years.

10 Disposal

ATTENTION ATTENTION Environmental hazard due to improper disposal!

- ▶ ▶ It is strictly prohibited to improperly dispose of operating materials, product components or parts thereof (e.g. in bodies of water, with household waste, etc.).
- ▶ ▶ Dispose of all product components in accordance with country-specific laws and the guidelines applicable at the place of operation.



Pergola
ROOM

Pergola Room USA LLC 23
Columbus Ave Staten Island
NY 10304 +1 800 215 0 216

Product: Easy Roof system
Type: EASY
V 1.1 – 01/2024
pergolaroom.com